

# LED SECURITY WALL LIGHT

MODEL: ME02205X-XXXX

## USE AND CARE GUIDE

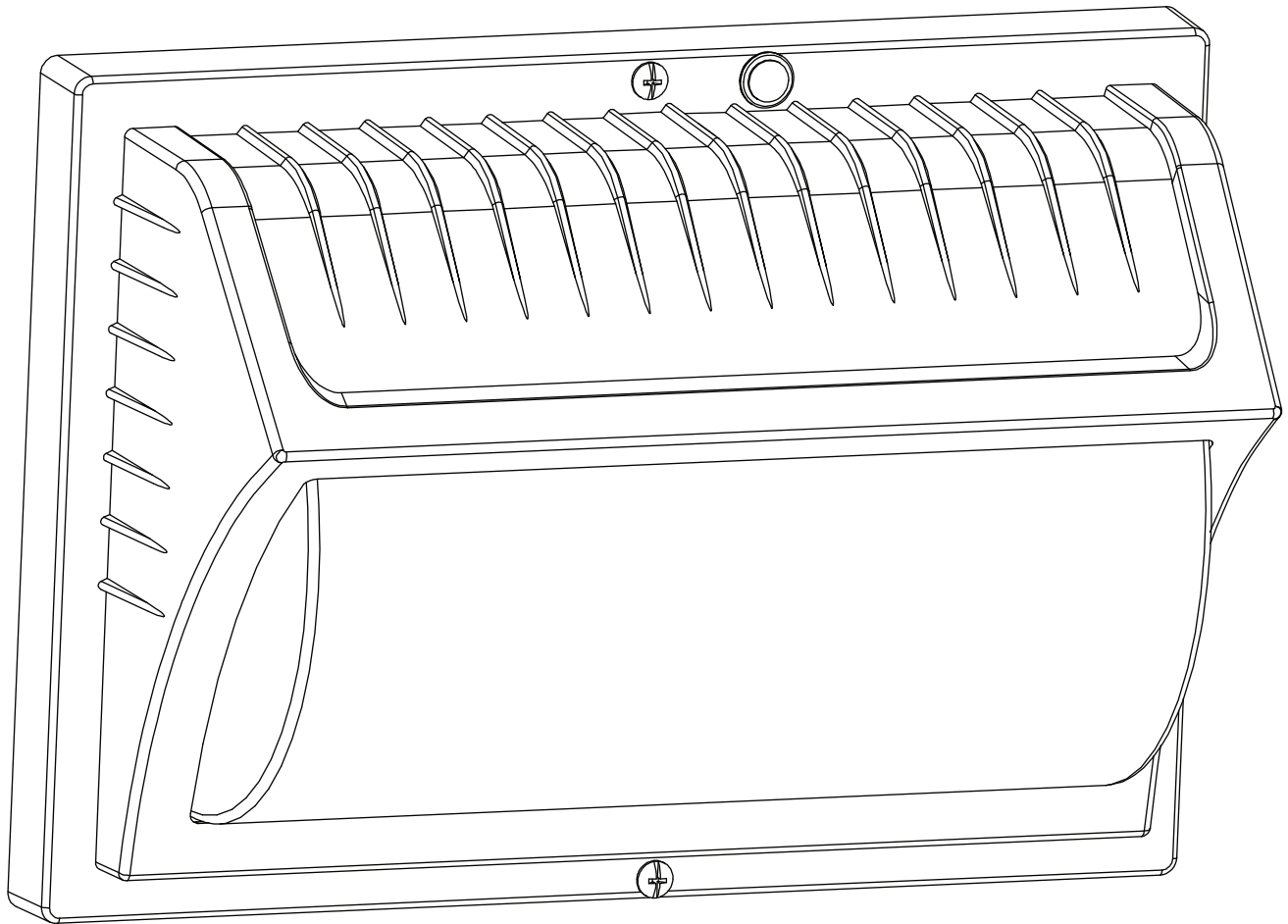

## SAFETY INFORMATION

**WARNING:** Read all safety precautions and installation instructions carefully before installing or servicing this fixture. Failure to comply with these instructions could result in a potentially fatal electric shock and/or property damage.

- To reduce the risk of electrical shock or other personal injury, ensure the power is turned **OFF** at the fuse or breaker box before making any electrical connections.
- To reduce the risk of electrical shock, and to assure proper operation, this fixture must be adequately grounded. To accomplish proper grounding, there must be a separate ground wire (yellow/green) contact between this fixture and the ground connection of your main power supply panel.
- Do not handle any energized fixture or attempt to energize any fixture with wet hands or while standing on a wet or damp surface or in water.
- It is recommended that a qualified electrician perform all wiring. This fixture must be wired in accordance with all national and local electrical codes.
- This fixture is intended to be used for general outdoor lighting, in wet locations, and should be mounted at least 8 ft. above the ground.
- Assure that the fixture is mounted onto a structurally sound surface that will support the fixture.
- This fixture is designed for use in a 120VAC, 60Hz fused circuit. Do not use on a dimming circuit.
- Do not look into the lights.

THIS PRODUCT MUST BE INSTALLED IN ACCORDANCE WITH THE APPLICABLE INSTALLATION CODE BY A PERSON FAMILIAR WITH THE CONSTRUCTION AND OPERATION OF THE PRODUCT AND THE HAZARDS INVOLVED.

## PRE-INSTALLATION

### PLANNING INSTALLATION

- Turn off the electrical power at the fuse or circuit breaker box before installing or servicing any part of this fixture.
- Carefully remove the fixture from the carton and check that all parts are included. Be careful not to misplace any of the screws or parts needed for installing the fixture.

### HARDWARE INCLUDED

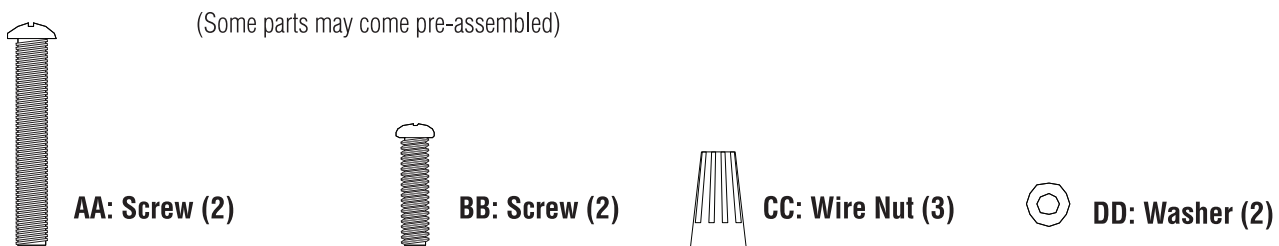

**PARTS**

A - Light fixture

B - Mounting bracket

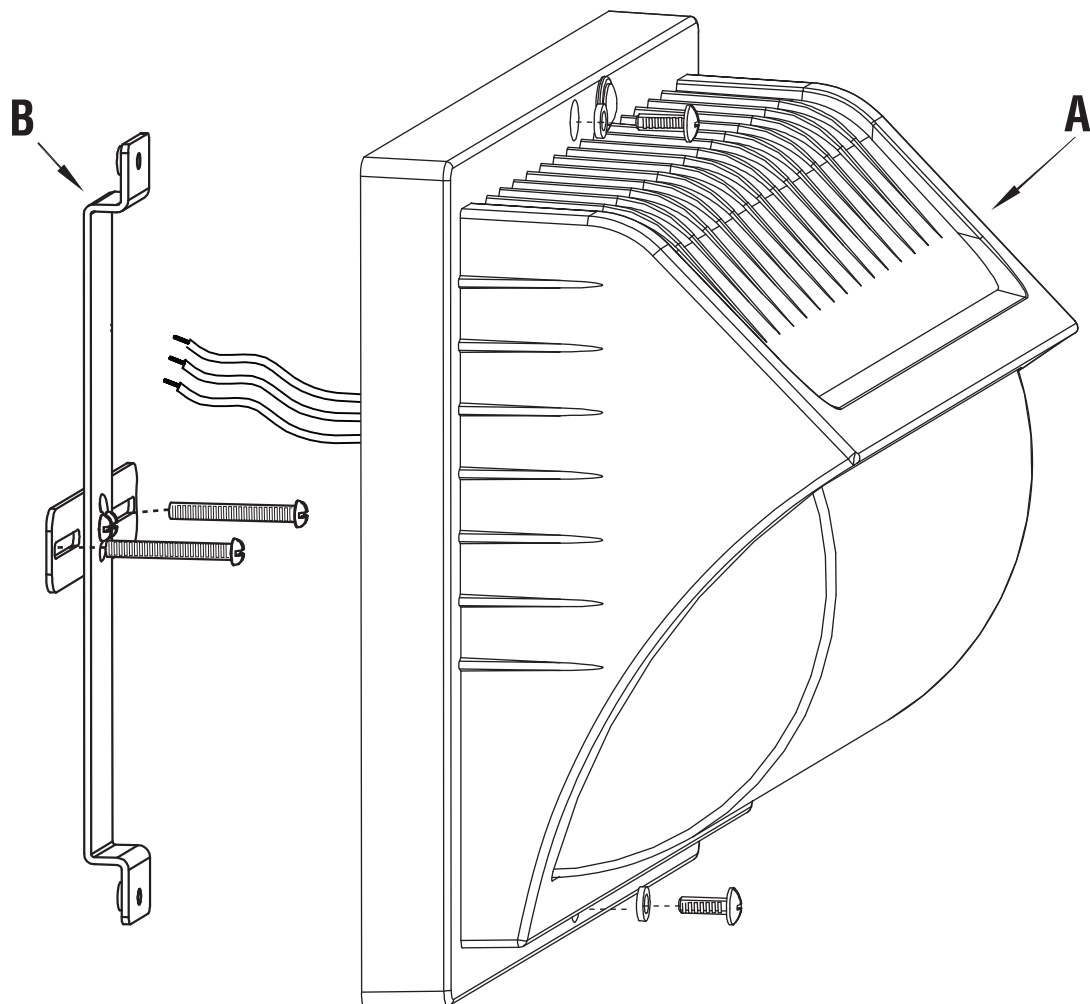

# INSTALLATION

**CAUTION:** Before beginning installation turn off the circuit breaker and light switch.

- This fixture is suitable for wall or eave mount only. Not suitable for ground mount installation. IMPORTANT: Do not use with dimmers or timers.
- Junction box is required for the assembly.
- For best performance, mount the fixture 8-12 feet above the ground.

## INSTALLING THE MOUNTING BRACKET

1. Thread the two screws (AA) through the mounting bracket (B).
2. Attach mounting bracket (B) with screws to junction box and tighten so bracket is firmly in place.

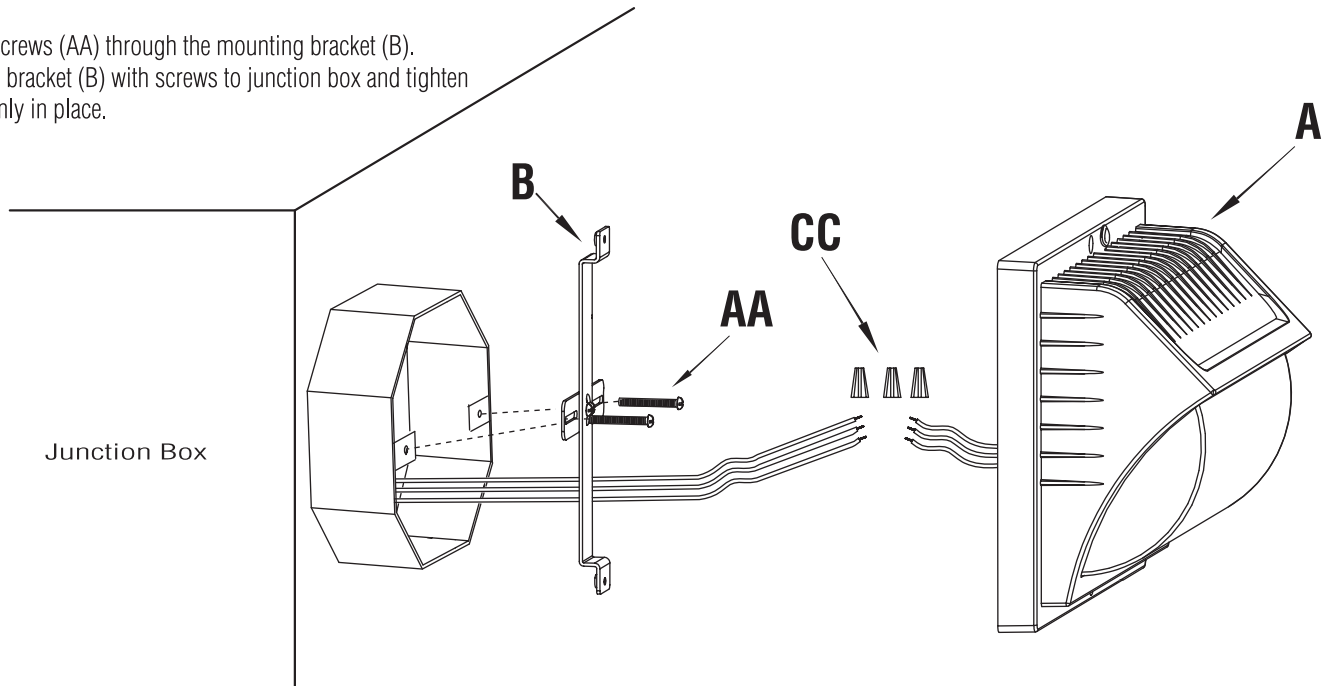

## CONNECTING THE WIRES

1. Connect the house ground wire to the fixture ground (yellow/green) wire using the wire nut (CC).
2. Connect the fixture black wire to the house black wire and the fixture white wire to the house white wire using the wire nuts (CC).

**NOTE:** For proper connection, place the wire nut over wires and twist clockwise until tight.

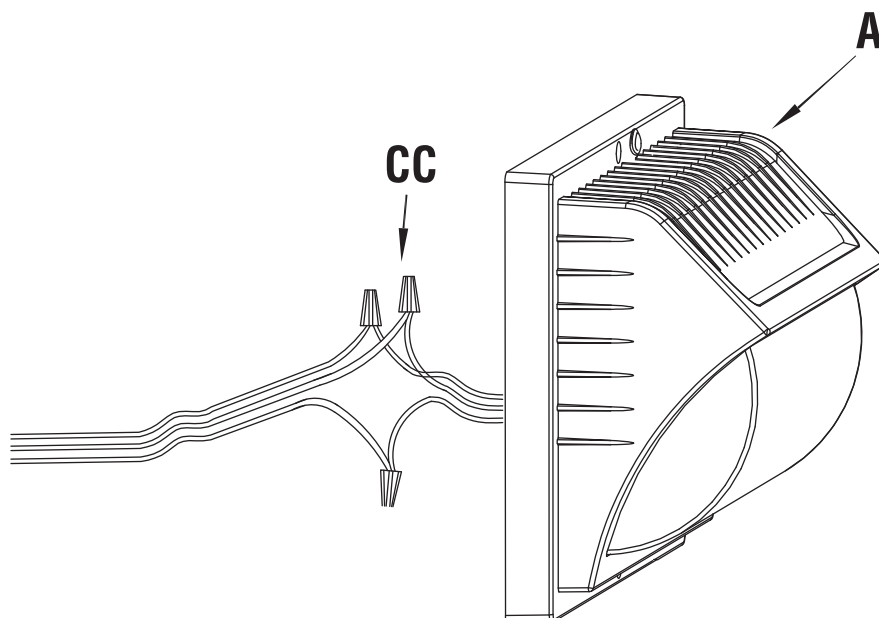

### MOUNTING THE FIXTURE

1. Line up the holes on the light fixture (A) and the mounting bracket (B).
2. Place the screws (BB) through washers (DD) into the light fixture (A) and align with holes on mounting bracket (B). Tighten until firmly in place.
3. Apply silicone caulk (not included) around the edges of the cover plate to provide a watertight seal from rain and moisture.

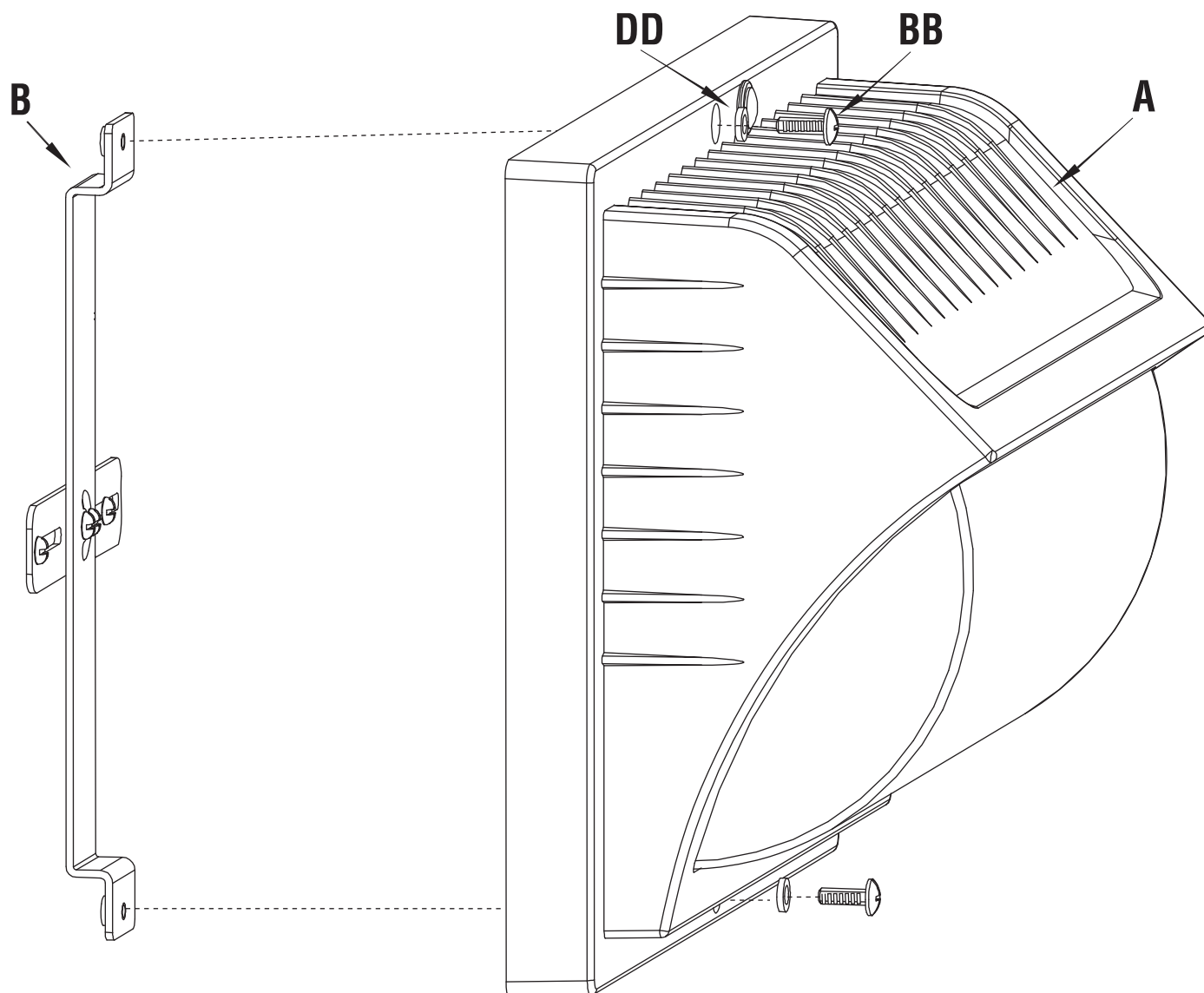

## OPERATION

### TESTING THE LIGHT FIXTURE

- Turn on the circuit breaker and light switch.
- To test operation during daylight, cover the photocell.

**NOTE: When first turned on wait about 1 minute for the circuitry to calibrate.**

## TROUBLESHOOTING

PROBLEM	POSSIBLE CAUSE	SOLUTION
Lights will not come on.	A. Light switch is turned off. B. Fuse is blown or circuit breaker is turned off. C. Incorrect circuit wiring.	A. Turn light switch on. B. Replace fuse or turn circuit breaker on. C. Verify that fixture is wired properly.

### FCC WARNING:

Warning: Changes or modifications to this unit not expressly approved by the party responsible for compliance could void the user authority to operate the equipment.

\*\*\*\*\*

Notes: This equipment has been tested and found to comply with the limits for a Class B digital device, pursuant to Part 15 of the FCC Rules. These limits are designed to provide reasonable protection against harmful interference in a residential installation. This equipment generates, uses and can radiate radio frequency energy and, if not installed and used in accordance with the instructions, may cause harmful interference to radio communications.

However, there is no guarantee that interference will not occur in a particular installation. If this equipment does cause harmful interference to radio or television reception, which can be determined by turning the equipment off and on, the user is encouraged to try to correct the interference by one or more of the following measures:

- 1) Reorient or relocate the receiving antenna.
- 2) Increase the separation between the equipment and receiver.
- 3) Connect the equipment into an outlet on a circuit different from that to which the receiver is connected.
- 4) Consult the dealer or an experienced radio/TV technician for help.